

User's manual rel 1.4 GB

# Nick **NRG1201**



**D.T.S. Illuminazione s.r.l.**

Via Fagnano Selve 12/14

47843 Misano Adriatico (RN) ITALIA Tel +39 0541 611131 Fax +39 0541 611111 [info@dts-lighting.it](mailto:info@dts-lighting.it) <http://www.dts-lighting.it>

**Made in Italy**

Le informazioni contenute in questo documento sono state attentamente redatte e controllate. Tuttavia non è assunta alcuna responsabilità per eventuali inesattezze. Tutti i diritti sono riservati e questo documento non può essere copiato, fotocopiato, riprodotto per intero o in parte senza previo consenso scritto della D.T.S .

D.T.S. si riserva il diritto di apportare senza preavviso cambiamenti e modifiche estetiche , funzionali o di design a ciascun proprio prodotto. D.T.S non assume alcuna responsabilità sull'uso o sull'applicazione dei prodotti o dei circuiti descritti.

The information contained in this publication has been carefully prepared and checked. However, no responsibility will be taken for any errors. All rights are reserved and this document cannot be copied, photocopied or reproduced, in part or completely, without prior written consent from D.T.S.

D.T.S. reserves the right to make any aesthetic, functional or design modifications to any of its products without prior notice. D.T.S. assumes no responsibility for the use or application of the products or circuits described herein.

Les informations contenues dans le présent manuel ont été rédigées et contrôlées avec le plus grand soin. Nous déclinons toutefois toute responsabilité en cas d'éventuelles inexactitudes. Tous droits réservés. Ce document ne peut être copié, photocopié ou reproduit, dans sa totalité ou partiellement, sans le consentement préalable de D.T.S.

D.T.S. se réserve le droit d'apporter toutes modifications et améliorations esthétiques, fonctionnelles ou de design, sans préavis, à chacun de ses produits. D.T.S. décline toute responsabilité sur l'utilisation ou sur l'application des produits ou des circuits décrits.

Las informaciones contenidas en este documento han sido cuidadosamente redactadas y controladas. Con todo, no se asume ninguna responsabilidad por eventuales inexactitudes. Todos los derechos han sido reservados y este documento no puede ser copiado, fotocopiado o reproducido, total o parcialmente, sin previa autorización escrita de D.T.S.

D.T.S. se reserva el derecho a aportar sin previo aviso cambios y modificaciones de carácter estético, funcional o de diseño a cada producto suyo. D.T.S. no se asume responsabilidad de ningún tipo sobre la utilización o sobre la aplicación de los productos o de los circuitos descritos.

**INDEX:**

<b>1-SYMBOLS.....</b>	<b>4</b>
<b>2-GENERAL WARNING .....</b>	<b>5</b>
<b>3-GENERAL WARRANTY CONDITIONS.....</b>	<b>5</b>
<b>4-TECHNICAL SPECIFICATIONS.....</b>	<b>5</b>
<b>5-ACCESSORIES .....</b>	<b>7</b>
<b>6-IMPORTANT SAFETY INFORMATION.....</b>	<b>8</b>
6.1 Fire prevention.....	8
6.2 Prevention of electric shock.....	8
6.3 Safety .....	8
6.4 Level of protection against the penetration of solid and liquid objects .....	8
6.5 Waste Electrical and Electronic Equipment directive.....	8
<b>7-VOLTAGE AND FREQUENCY .....</b>	<b>9</b>
<b>8-INSTALLATION .....</b>	<b>9</b>
8.1 Safety cable.....	9
8.2 Protection against liquids.....	10
8.3 Movement.....	10
8.4 Risk of fire .....	10
8.5 Forced ventilation .....	10
8.6 Ambient temperature .....	10
<b>9-MAINS CONNECTION.....</b>	<b>11</b>
9.1 Protection .....	11
<b>10-DMX SIGNAL CONNECTION.....</b>	<b>12</b>
10.1 DMX addresses.....	13
10.2 Selecting the DMX address .....	13
<b>11-FIRMWARE UPDATING .....</b>	<b>13</b>
<b>12-DISPLAY FUNCTIONS .....</b>	<b>14</b>
<b>13-PERIODIC CLEANING .....</b>	<b>23</b>
<b>14-PERIODIC CONTROLS .....</b>	<b>23</b>
<b>15-DMX PROTOCOL .....</b>	<b>24</b>

**1- SYMBOLS**

Graphic symbols used on this manual:



**THIS SYMBOL INDICATES A HOT SURFACE**



**THIS SYMBOL INDICATES ELECTRIC SHOCK RISK**



**THIS SYMBOL INDICATES GENERAL RISK**

$t_a$  40°C

**THIS SYMBOL INDICATES THE MAXIMUM OPERATING AMBIENT TEMPERATURE**



**THIS SYMBOL MEANS “SUITABLE FOR INDOOR USE ONLY”**



**THIS SYMBOL MEANS “SUITABLE FOR MOUNTING ON NORMALLY FLAMMABLE SURFACES”**

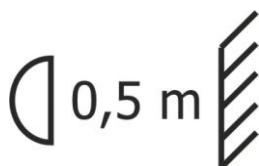

**THIS SYMBOL INDICATES THE MINIMUM DISTANCE FROM THE ILLUMINATED OBJECTS**



**THIS SYMBOL MEANS “DO NOT STARE AT THE OPERATING LIGHT SOURCE”**



**THIS SYMBOL INDICATES PHOTOBIOLOGICAL SAFETY**

Risk Group 2



**THIS SYMBOL INDICATES THE EUROPEAN COMMUNITY DIRECTIVE 2012/19/EC ON WASTE ELECTRICAL AND ELECTRONIC EQUIPMENT (WEEE)**

## **2- GENERAL WARNING**

Read the instruction contained in this user manual carefully, as they give important information regarding safety during installation , use and maintenance.

The device is not for household use and must be installed by a qualified electrician or experienced person.

Always disconnect the device from the mains before maintenance.

The device must always be equipped with an efficient ground connection.



**WARNING!**  
**NEVER EXPOSE THE FRONT LENS  
 TO SUNLIGHT FROM ANY ANGLE  
 TO AVOID DAMAGE OF  
 HEAD INTERNAL PARTS.**

Front lens could become powerful magnifying glass if exposed towards the sun or any strong artificial light source; this can cause damage of head internal parts, even for few seconds and even when the unit is off.

The last command before switch off: point the front lens down towards the ground.

## **3- GENERAL WARRANTY CONDITIONS**

The unit is guaranteed for 36 months from the date of purchase against manufacturing material defects.

## **4- TECHNICAL SPECIFICATIONS**

### **DTS Product codes:**

03.LDR006.FFP

NICK NRG 1201 FC FPR Black finish

### **LED Technology**

\* 30 x FULL RGBW LEDs

### **Optical group**

\* 8°- 50° linear motorized zoom with high-efficiency optical system

\* Uniform projection on surfaces, from very wide Wash to PC Beam

### **Colour generation**

\* 16 million colours

\* Wide palette of pure uniform whites with variable linear colour temperature (2700K – 8000K)

**Interface / Control / Programming**

- \* Multi-function OLED graphic colour display + 4 soft keys: control / management / monitoring of the main parameters
- \* Controlled via DMX 512 and RDM standard digital communication protocols
- \* Wireless ready
- \* Ethernet ready
- \* Internal updatable operating system

**DMX**

20 DMX channels

**Pan & Tilt**

- \* 'FPR' system (DTS patent)
- Pan: limitless pan rotation, in both directions; 360° rotation in 0,89 sec.  
Tilt 258°: 1,2 sec.
- \* 16-bit movement resolution
  - \* 4 Selectable speed ranges

**Power supply**

- \* Full-range 100-240Vac 50-60 Hz
- \* Power consumption: 450VA

**Connections**

- \* DMX: XLR 3-pole and 5-pole In/Out panel connectors
- \* Power supply: PowerCON In/Out panel connectors

**Internal safety devices**

Overvoltage and overtemperature circuit protection

**Operating ambient temperature**

-10° / 40°

**Weight**

10,5 Kg

**International certifications**

CE certification  
LED Class: Class II LED product

## Dimensions

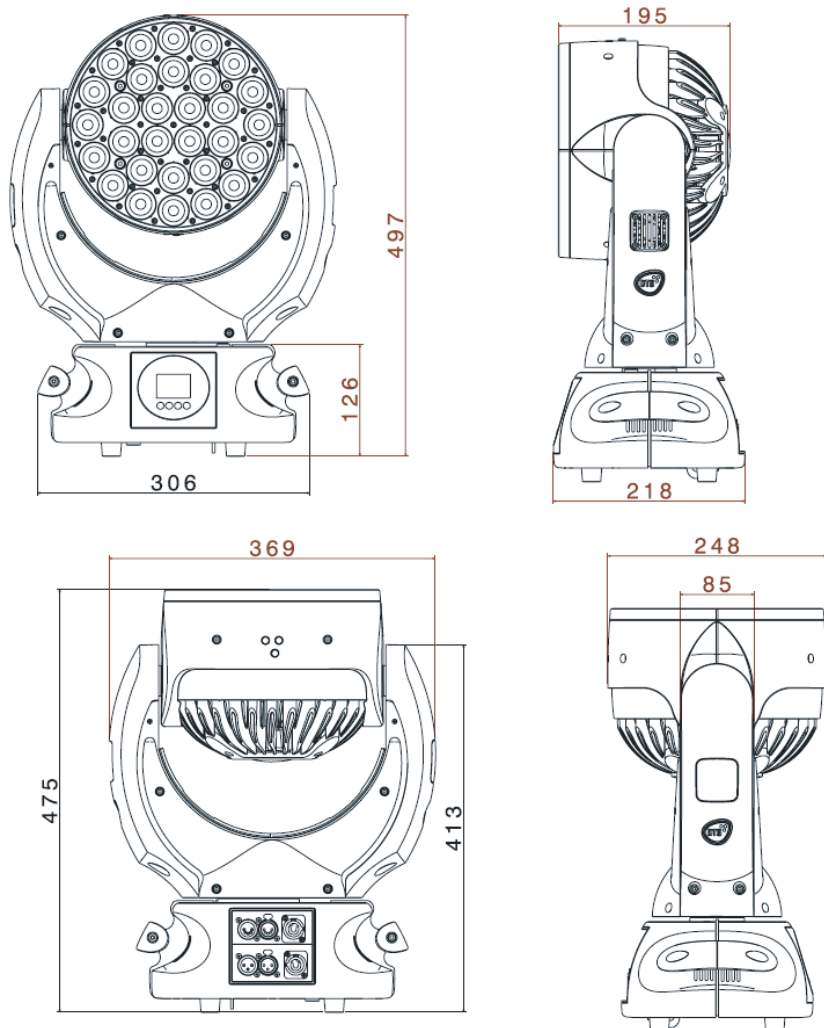

Packaging Dimensions (LxWxH)  
540 x 440 x 420 mm  
Weight: 14,5 Kg

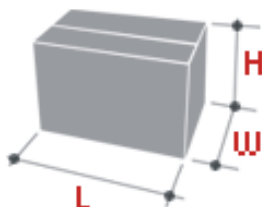

## 5- ACCESSORIES

### As standard

- 1 x PowerCON female cable connector (code 0520P014)
- 1 x XLR 5 Pins female cable connector (code 0508B147)
- 1 x XLR 5 Pins male cable connector (code 0508B148)
- GQUICK clamp with “Fast Lock” connection 1/4 turn (code 0521A014)
- User’s manual

### Optional (on request)

- Flightcase for 4 units (code 0521C059.1)
- DTS Dongle Firmware Uploader (code 03.LA.206)
- Aliscaf clamp for tube diameter 50 mm (Max load 100 Kg) (code 0521A008)  
(indicated for any kind of loads vertical / horizontal)
- Professional Quick trigger clamp (Max load 100 Kg) (code 0521A037) (not indicated for horizontal load)
- G60 “C” Clamp (Max load 50 Kg) (code 0521A004) (not indicated for horizontal load)
- Omega bracket with “Fast Lock” connection ¼ turn (code 02K00467)
- Safety cable 3 mm x 60 cm (Max load 60 Kg) (code 0521A010)

## **6- IMPORTANT SAFETY INFORMATION**

### **6.1 Fire prevention:**

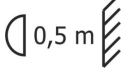

- It is permissible to place the unit on normally flammable surfaces. Suitable for mounting on normally flammable materials surfaces greater than 200°C with some combustion time lag.
- Minimum distance from the closest illuminable surface: 0,5 m. 
- Replace any blown or damaged fuses only with those of identical value (T 5A 250V). Refer to the wiring diagram if there is any doubt.
- Connect the projector to mains power via a thermal magnetic circuit breaker.

### **6.2 Prevention of electric shock:**



- High voltage is present inside the unit. Unplug the unit prior to performing any function which involves touching the inside of the moving head.
- The level of technology inherent in the NICK NRG 1201 requires the assistance of specialised personnel for all servicing. Please refer to an authorised DTS service centre.
- A good earth connection is essential for proper functioning of the projector.
- Never connect the unit without proper earth connection.
- The fixture should be located in places with a good air ventilation.

### **6.3 Safety:**



-Risk Group 2 product according to EN 62471. Risk Group 2  
CAUTION. Do not look directly into the light output. May be harmful to the eyes and skin.



- Do not stare at the operating light source.
- The light source contained in this luminaire shall only be replaced by the Manufacturer or his service agent or a similar qualified person.
- The projector should always be installed with bolts, clamps and other tools that are capable of supporting the weight of the unit.
- Always use a second safety cable to sustain the weight of the unit in case of the failure of the main fixing point.
- The external surface of the unit, at various points, may exceed 50°C. Never handle the unit until at least 5 minutes have elapsed since the projector was turned off.
- Never install the fixture in an enclosed area lacking sufficient air flow. The ambient temperature should not exceed 40°C.  $t_a$  40°C



### **6.4 Level of protection against the penetration of solid and liquid objects:**



-The projector is classified as an ordinary appliance and its protection level against the penetration of solid and liquid objects is IP 20.

Suitable for indoor use only.



### **6.5 Waste Electrical and Electronic equipment (WEEE) directive:**



- The machine, accessories and packaging should be sorted for environmental-friendly Recycling.
- For EC countries: according to the European Directive 2012/19/EC for Waste Electrical and Electronic Equipment and its implementation into national right, luminaires that are no longer usable must be collected separately and disposed of in an environmentally correct manner.



## 7- VOLTAGE AND FREQUENCY

NICK NRG 1201 operates at 100-240Vac 50-60 Hz.

## 8- INSTALLATION

NICK NRG 1201 may be either floor or ceiling mounted.

For floor mounting installations, the NICK NRG 1201 is supplied with four rubber mounting feet on the base.

For ceiling mounted installations, we recommend the use of appropriate clamps to fix the unit to the mounting surface.

The supporting structure from which the unit is hung should be capable of bearing the weight of the unit, as should any clamps used to hang it. The structure should also be sufficiently rigid so as not to move or shake whilst the NICK NRG 1201 is moving.

Four 1/4 turn Fast Lock connections placed in the base of the unit allow to hang the NICK NRG 1201 by using the G-QUICK clamp provided in the box.



### 8.1- Safety cable



We recommend the use of a safety cable or chain connected to the NICK NRG 1201 and to the suspension truss in order to avoid the fixture accidentally falling should the main fixing point fail.

Make sure that the iron cable or chain can bear the weight of the entire unit.

You may attach the safety chain/cord to the attachment point (A) located on the base of the fixture, as shown in the picture below.

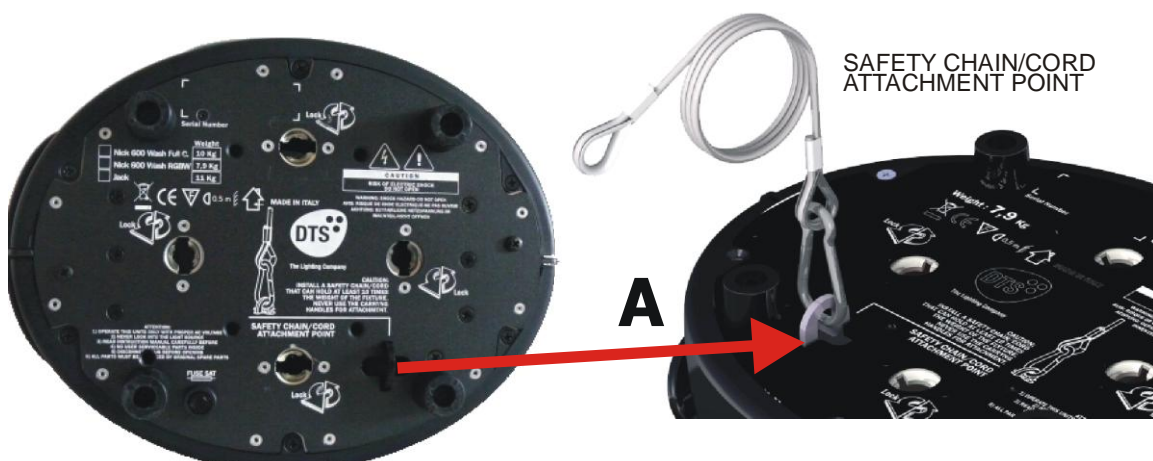

## 8.2 Protection against liquids



The projector contains electric and electronic components which should under no circumstances come into contact with oil, water or any other liquid. The proper unit functioning would be compromised should this occur.

## 8.3- Movement

Pan: limitless pan rotation, in both directions; 360° rotation in 0,89 sec.

Tilt 258°: 1,2 sec.

Do not place any obstructions in the path of the projector's movement.



**WARNING**

Do not place any object in the path of the projector's movement

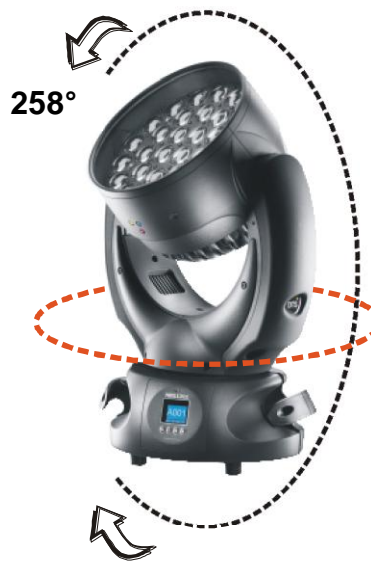

## 8.4- Risk of fire

Each fixture produces heat and must be installed in a well-ventilated place. It is permissible to place the unit on normally flammable materials surfaces. Suitable for mounting on normally flammable materials surfaces greater than 200°C with some combustion time lag.

Minimum distance from the object being illuminated is 0,5 m.

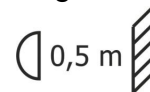

## 8.5- Forced ventilation

You will note, on inspection, that the unit features various air inlets and cooling fans. These should, under no circumstances, be blocked or obstructed whilst the projector is in operation. Doing so could cause the fixture to seriously overheat thereby compromising its proper operation.

## 8.6- Ambient temperature

The projector should never be installed in places that lack a constant air flow.

The ambient temperature should not exceed 40°C.  $t_a \leq 40^\circ\text{C}$

## 9- MAINS CONNECTION

NICK NRG 1201 operates at 100-240Vac 50-60 Hz.

Prior to connecting the unit to your mains supply, ensure that the model in your possession correctly matches the mains supply available.

For connection purposes, ensure that your plug is capable of supporting 2,5 amps at 230Vac, or 5 amps at 100Vac.

Strict adherence to regulatory norms is strongly recommended.

### MAINS OUTPUT 100-240Vac 50-60 Hz (MAX 16A)

Max 6 NICK NRG 1201 units @ 230Vac

Max 3 NICK NRG 1201 units @ 100Vac

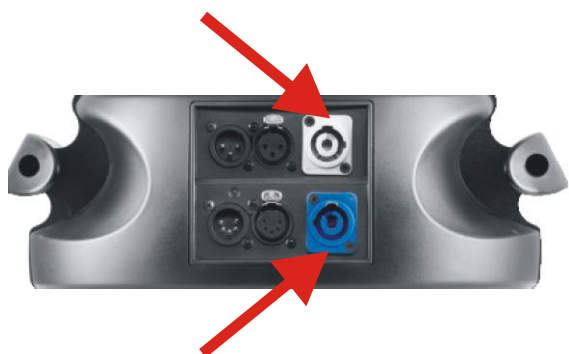

### MAINS INPUT 100-240Vac 50-60 Hz

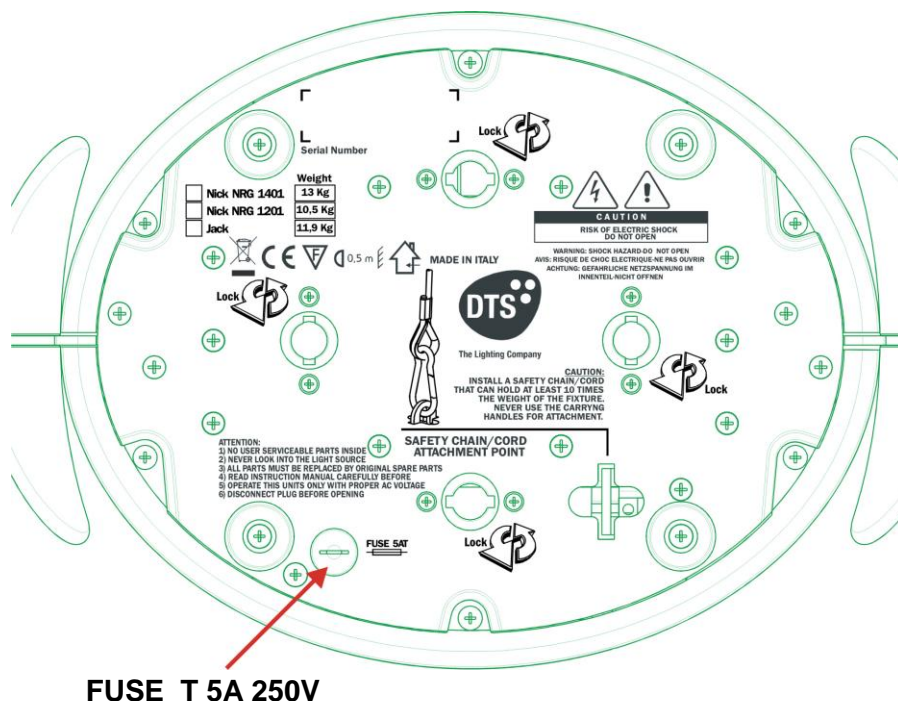

### 9.1- Protection



The use of a thermal magnetic circuit breaker is recommended for each NICK NRG 1201.

## 10- DMX SIGNAL CONNECTION

The unit operates using the digital DMX 512 signal.

Connection between the mixer and the projector or between projectors must be carried out using a two pair screened  $\varnothing$  0.5 mm cable and a XLR 5 or 3 pins connector.

Ensure that the conductors do not touch each other.

Do not connect the cable ground to the XLR chassis.

The plug housing must be isolated. Connect the mixer signal to the DMX IN projector plug and connect it to the next projector by connecting the DMX OUT plug on the first projector to the DMX IN plug of the second one.

This way, all the projectors are cascade connected.

**NB. If the display showing the DMX address flashes, then one of the following errors has occurred:**

- DMX signal not present
- DMX address not valid
- DMX reception problem

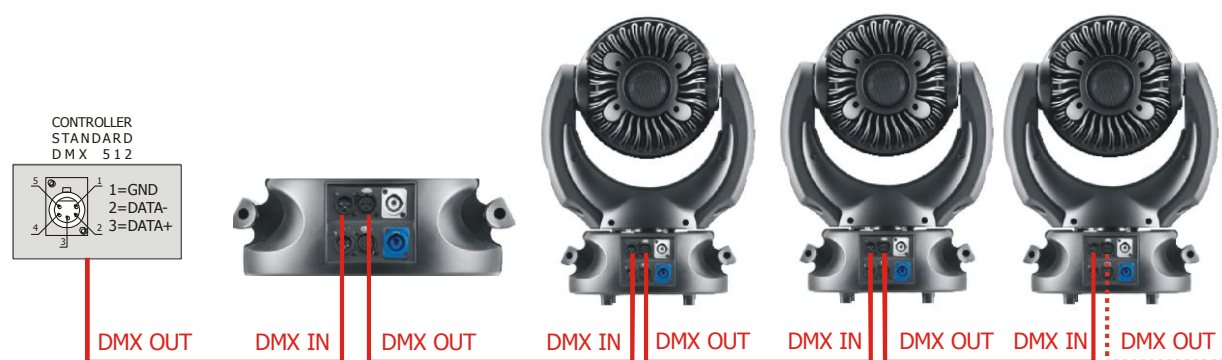

For Installations where long distance DMX cable connections are needed, we suggest to use a DMX terminator.

The DMX terminator is a male XLR 3-5 pins connector with a 120 ohm resistor between pin 2 and 3.

The DMX terminator must be plugged into the last unit (DMX out panel connector) of the DMX line.

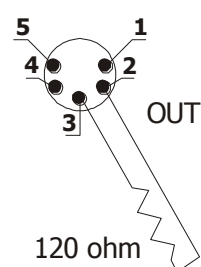

PLACE A 120 OHM RESISTOR BETWEEN PIN 2 AND 3 OF A MALE XLR CONNECTOR AND PLUG IT INTO THE DMX OUT PANEL CONNECTOR OF THE LAST UNIT CONNECTED TO THE DMX LINE

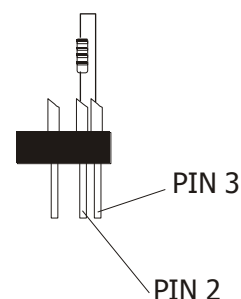

## **10.1-DMX Addresses**

NICK NRG 1201 can be controlled with 20 DMX channels.

In order to use the unit in 20 channels, set the following addresses on the mixer:

Projector 1	A001	
Projector 2	A021	If you want to select the next projector, just add "20"
Projector 3	A041	
.....	A....	
projector 6	A101	

## **10.2-Selecting the DMX address**

- 1) Press the UP-DOWN key until you reach the required DMX channel. The numbers on the display will start to flash (but the new DMX address hasn't yet been set).
- 2) Press ENTER to confirm your selection. The numbers on the display will stop flashing and the projector is now setted to the new DMX address.

TRICKS:

if you keep pushed the UP or DOWN keys, the channels are calculated more quickly and you get a faster selection.

## **11- FIRMWARE UPDATING**

To update the firmware release of the NICK NRG 1201 you need:

- DTS Dongle Firmware Uploader (code 03.LA.206).
- "DTS Firmware Upgrade Utility v.2.02" program installed on PC.
- Latest firmware release available for NICK NRG 1201 unit.

### **Updating the firmware release.**

Please follow the procedure below to perform the update:

1. Connect the DTS Dongle Firmware Uploader to a spare USB port on the PC.
2. Connect the unit DMX input to the DTS Dongle Firmware Uploader DMX output with a standard DMX cable and turn ON the unit.
3. Send the new firmware release into the unit by using "DTS Firmware Upgrade Utility v.2.02" program. At the end of the procedure, the unit will reset.

For more information please refer to an authorised DTS service centre.

## 12- DISPLAY FUNCTIONS

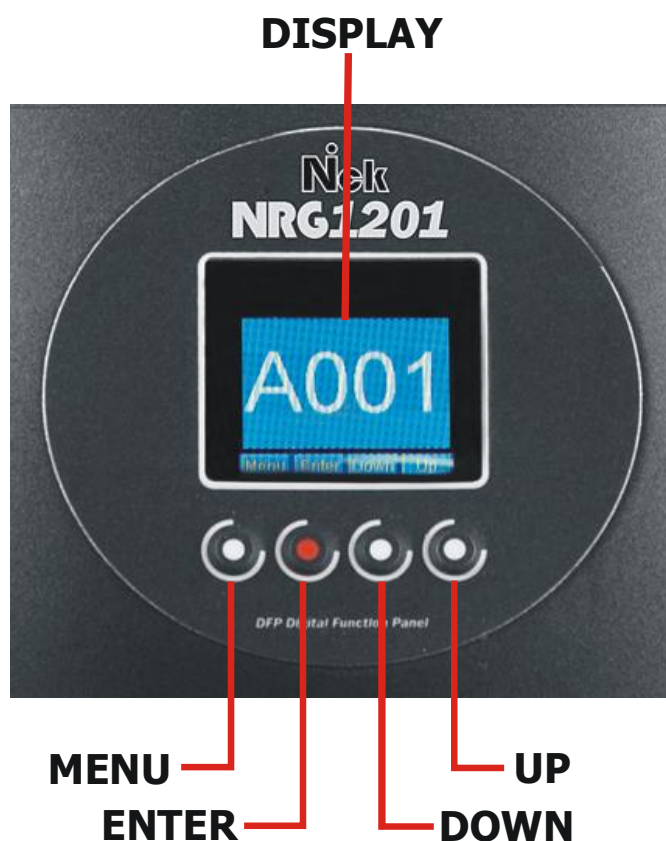

### DISPLAY FUNCTIONS

The NICK NRG 1201 display panel shows all the available functions. Using these functions, it is possible to change some of the parameters and add some functions. Changing the DTS setting can vary the functions of the unit so that it does not respond to the DMX 512 used to control it. Carefully follow the instructions below before carrying out any variations or selections.

NOTE: the symbol  shows which key has to be pushed to obtain the desired function.

<b>FIRMWARE RELEASE</b>	<b>1.35</b>
<b>RDM Device Model ID</b>	<b>0x0D13</b>
<b>DMX Personality ID</b>	<b>0x01 "20CH With FAR"</b>

## 12- DISPLAY FUNCTIONS



Display



### DISPLAY POSITION / STAND-BY

**Display Position:**  
Reverses display's reading depending on the mounting position (on the ground or suspended).

**Display Stand-by:**  
To turn off the display (after 30 seconds) or leave it always on.

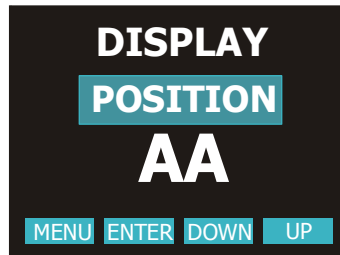

Display Position  
ON THE GROUND (Default)  
SUSPENDED

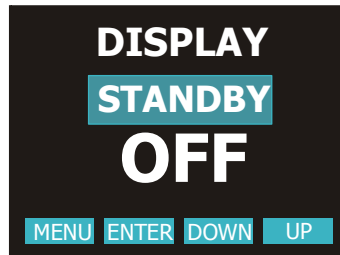

Display Standby  
OFF = Display Stand-by disabled (Default)  
ON = Display goes OFF after 30 seconds



DMX Set



DMX MODE / MACRO / DIMMER DELAY  
DMX Mode  
20 channels

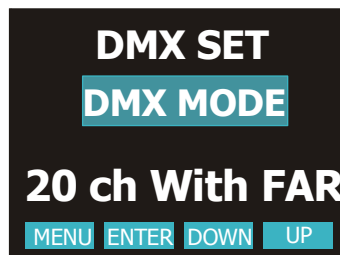

DMX Mode  
20 channels



**MACRO**  
Macro Mode:  
STD = Standard (Default)  
EXT = Extended; enable rainbow effects on Macro channel (DMX ch 16)



MACRO  
STD = Standard mode enabled (Default)  
EXT = Extended; enable rainbow effects on Macro channel (DMX channel 16)

**DIMMER DELAY**  
This menu allows to select the value of the delay (in seconds) for the Dimmer channel reaction to DMX or program variation

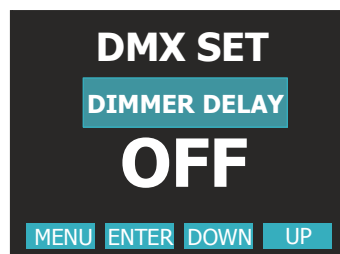

DIMMER DELAY  
Range: OFF / 0.1 - 2.0 sec.  
Default = OFF

## 12- DISPLAY FUNCTIONS



LED



**MIN / MAX COMPATIBILITY**  
This menu allows to set same RGBW light output intensity and colour temperature between new and old units. Red, Green, Blue and White min/max values are activated into the “service” menu.

**SMOOTH VALUE**  
This menu allows to select the value of the delay (in milliseconds) for RGBW and Dimmer channels reaction to DMX or Program variation.

4 = 25 ms delay (Fast response)  
20 = 250 ms delay (Slow response)

**GAMMA CORRECTION**  
This menu allows to select between Linear current output or Quadratic current output for LEDs  
Default = Quadratic

**OUTPUT FREQUENCY**  
This menu allows to adjust the PWM frequency value (Hz) in order to reduce flickering in the process of your camera recordings

**LED CURRENTS**  
This menu shows the value of the real time current (mA) for the Red, Green, Blue and White LEDs

**BOOST DRIVING**  
This menu allows to increase the LED's current from 2,1A to 3A.

**CTC MODE**  
This menu allows to select the color temperature range available on the DMX Channel 15 “CTC”.  
STANDARD = color temperature correction from 2700K to 8000K (Default).  
COMPATIBILITY = color temperature correction from 2700K to 8000K with different RGBW levels to have the same “Whites” colour temperature between NICK NRG 1201 and the other DTS range LED units (NICK NRG 501, NICK NRG 801 and WONDER).  
EXTENDED = color temperature correction from 2700K to 20500K.

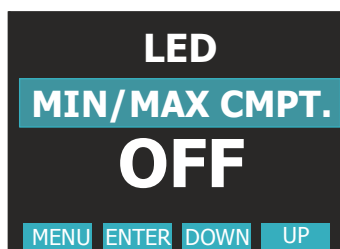

MIN / MAX CMPT.  
Default = OFF

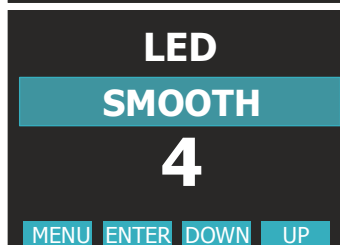

SMOOTH  
Range = Off – 20  
Default = 4

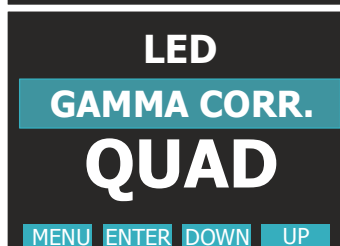

GAMMA CORRECTION  
Linear = Linear current output  
Quadratic = Linear light output (default)

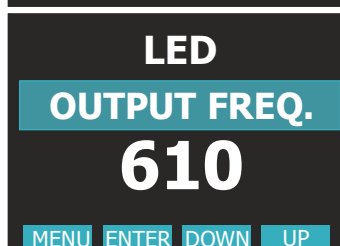

OUTPUT FREQUENCY  
Range = 610 Hz – 10 KHz  
Default = 610 Hz

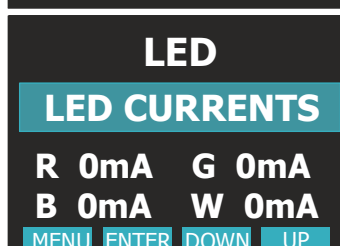

LED CURRENTS  
Real time currents for LEDs monitoring

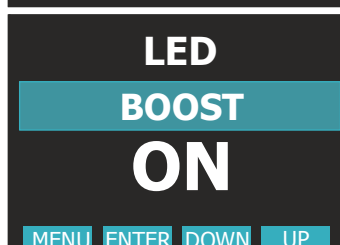

BOOST  
With BOOST active, the LED's current is set to 3A (30% more gain)  
Default = ON



CTC MODE  
Default = STANDARD



## 12- DISPLAY FUNCTIONS



AUTO



**AUTOMATIC MODE**  
Automatic demo game  
without DMX controller

### STEP 01/16

Chase with 16 steps previously  
created in REC MODE  
Speed time, Wait time, Dimmer, Pan,  
Tilt and Zoom values selectable by user.

### PERSONAL COLOURS

RGBW, Dimmer, Shutter, Pan, Tilt and  
Zoom values selectable by user.

### RAINBOW

Rainbow colours effect.  
Speed time, Dimmer, Shutter, Pan,  
Tilt and Zoom values selectable by user.

### FIXED COLOURS

Sixteen Colour Macros as  
on "MACRO" channel.  
Dimmer, Shutter, Pan, Tilt and  
Zoom values selectable by user.

### WHITE MACROS

Sixteen macros for White  
color (from 2700K to 8000K  
for NICK NRG 1201 FC; from  
2700K to 6500K for NICK  
NRG 1201 CT).  
Dimmer, Shutter, Pan, Tilt and  
Zoom values selectable by user.

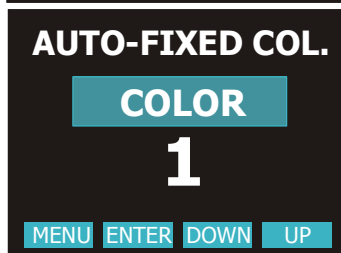
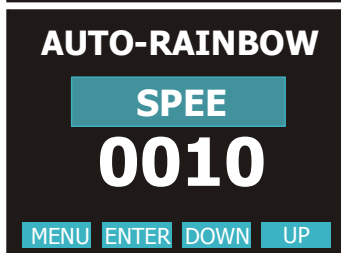
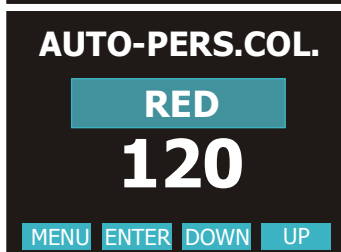
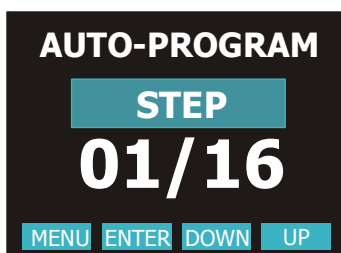
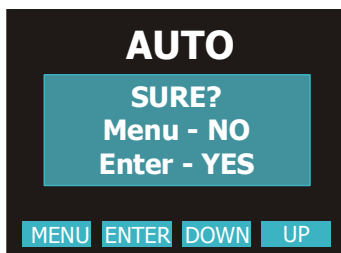

By setting all the units  
connected to the MASTER  
to DMX address 1, they will  
be synchronized with the  
Master unit following the  
chase selected on it,  
including TIME, WAIT,  
Pan&Tilt and Zoom position  
of the MASTER unit.



## 12- DISPLAY FUNCTIONS



### SLAVE MODE SETTING

This menu allow to set the NICK NRG 1201 as slave unit.

DMX signal must be present from MASTER unit (set in AUTO MODE) in order to ran the units in SLAVE mode.

By setting all the SLAVE units connected to the MASTER, to DMX address 1, them will be synchronized with the Master unit following the chase selected on it, but running their own Pan&Tilt and Zoom position.

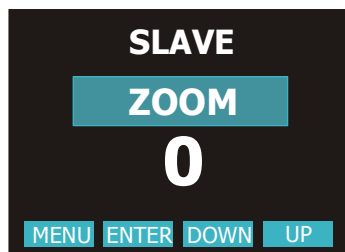
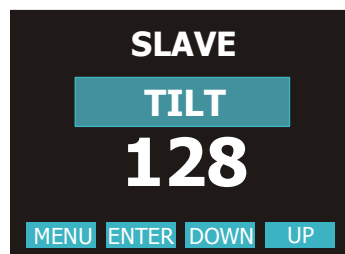
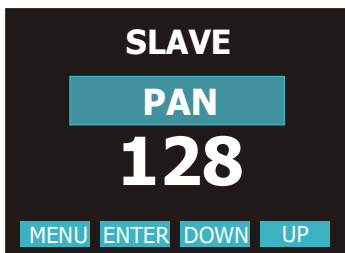

The SLAVE unit receive DMX signal from the MASTER unit. By setting all the SLAVE units connected to the MASTER, to DMX address 1, them will be synchronized with the Master unit following the chase selected on it, but running their own Pan&Tilt and Zoom position.



## 12- DISPLAY FUNCTIONS



### WIRELESS DMX

Wireless DMX enabled / disabled.  
By activating WDMX MODE, it will be possible to control NICK NRG 1201 via D.T.S. ANTENNA Wireless DMX Transmitter (cod. 03.E1271).

**Wireless DMX Receiver Kit (Cod. 03.LA.126) on NICK NRG 1201 is available on request.**



WIRELESS DMX SYSTEM  
DISABLED (Default)



WIRELESS DMX SYSTEM  
ENABLED



UNLINK = LOG OUT



Logging on NICK NRG 1201 (WIRELESS DMX must be enabled on the unit).

To log on the NICK NRG 1201 in the WIRELESS system simply press and quickly release the function button on the transmitter .

The transmitter will start flashing rapidly red/green scanning for new free receivers / NICK NRG 1201 units. When a NICK NRG 1201 logs on to the transmitter the LINK green light on transmitter starts to flash rapidly.

After approximately 10 seconds the transmitter will jump back to normal mode and continue transmitting data. The NICK NRG 1201 now try to synchronize to the transmitter.

When synchronized to the transmitter, 2 different modes are possible:

1. Antenna transmitter has detected and transmits a DMX signal, in this mode a solid green light is seen on the transmitter and solid display is seen on NICK NRG 1201.
2. No DMX signal connected, the Antenna transmitter will flash red/green; display blinking on NICK NRG 1201.

To log off NICK NRG 1201 from a transmitter simply select UNLINK function under WIRELESS DMX MENU and press ENTER.

When NICK NRG 1201 is logged off the display is blinking, meaning its available for log in on a new transmitter.

Logging out a NICK NRG 1201.

Select UNLINK function under WIRELESS DMX MENU and press ENTER.

When NICK NRG 1201 is logged off the display is blinking, meaning its available for log in on a new transmitter.

Logging out all NICK NRG 1201 linked to a transmitter.

Press and hold the function button of the transmitter for about 3 seconds. When the display is blinking on NICK NRG 1201, it mean that the units are logged out.

Transmitter, Status LED.

Flashing red/green, no dmx connected.

Solid green, dmx signal detected and transmitted.

Fast flashing red/green, log in mode (every free NICK NRG 1201 unit, not logged in to any other transmitter, will be logged on)

NICK NRG 1201 Status.

Display blinking, not logged on to a transmitter (free).

Solid display, logged on to a transmitter and receiving dmx data.

## 12- DISPLAY FUNCTIONS



### EMERGENCY

Emergency operating mode.  
By setting Emergency mode, it will be possible to select one of the 16 preprogrammed WHITE cues that will then ran if DMX signal is missing or not available.  
Useful for Emergency EXIT illumination on public areas.  
Dimmer level, Pan&Tilt and Zoom values selectable by user.



EMERGENCY  
Disabled = Default



EMERGENCY  
Enabled



WHITE (1-16)  
Default = WHITE 1



DIMMER  
Default = 255



PAN  
Default = 128

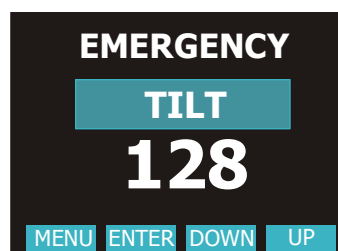

TILT  
Default = 128

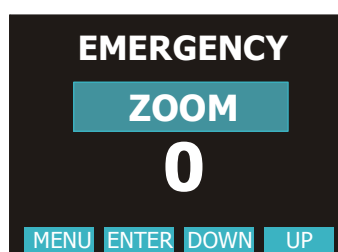

ZOOM  
Default = 0

## 12- DISPLAY FUNCTIONS

Menu Up-Down **DEFAULT SET** ENTER Up-Down

**DEFAULT SETTINGS**  
To restore default settings

**DEFAULT SET**

MENU ENTER DOWN UP

ENTER

**DEFAULT SET**

**SURE?**  
Menu - NO  
Enter - YES

MENU ENTER DOWN UP

Menu Up-Down **TEMPER. °C** ENTER

**TEMPERATURE**  
Unit temperature monitoring

**TEMPER. °C**

**028.7**

MENU ENTER DOWN UP

Menu Up-Down **TIME** ENTER Up-Down

**LIFE TIME**  
This menu shows the total unit  
life time and the RGBW LEDs  
life time

**TIME**

**UNIT**

**13 Hr - 08 min**

MENU ENTER DOWN UP

ENTER

**TIME**

**RED**

**0 Hr - 08 min**

MENU ENTER DOWN UP

**TIME**

**GREEN**

**0 Hr - 08 min**

MENU ENTER DOWN UP

**TIME**

**BLUE**

**0 Hr - 08 min**

MENU ENTER DOWN UP

**TIME**

**AMBER**

**0 Hr - 08 min**

MENU ENTER DOWN UP

## 12- DISPLAY FUNCTIONS



PAN INVERSION / TILT INVERSION /  
PAN SPEED / TILT SPEED /  
ZOOM SPEED / FANS SETTING /  
FAN MAX SPEED / RESET BY DMX /  
MOTORS FIRMWARE UPGRADE.

### PAN INVERSION

This menu allows to set the Pan movement. Normal or Reversed.

### TILT INVERTION

This menu allows to set the Tilt movement. Normal or Reversed.

### PAN SPEED

Pan Speed control (1-8)

### TILT SPEED

Tilt Speed control (1-8)

### ZOOM SPEED

Zoom Speed control (1-4)

### FANS SETTING

STUDIO mode = Low fans speed for a very low noise operation.

LIVE-TOUR mode = High fans speed: the LEDs always work at maximum power.

### FAN MAX SPEED

This menu' allows to select the internal fans speed.

### RESET BY DMX

This menu allows to enable / disable the Motors reset control (Pan&Tilt and Zoom) via DMX.

### MOTORS FIRMWARE UPGRADE

This menu allows to upgrade the firmware for Zoom and Pan&Tilt boards.

## SYSTEM

### PAN INVERSION

**NORM**

MENU ENTER DOWN UP

## SYSTEM

### TILT INVERSION

**NORM**

MENU ENTER DOWN UP

## SYSTEM

### PAN SPEED

**5**

MENU ENTER DOWN UP

## SYSTEM

### ZOOM SPEED

**1**

MENU ENTER DOWN UP

## SYSTEM

### FAN SETTING

**STUDIO**

MENU ENTER DOWN UP

## SYSTEM

### FAN MAX SPEED

**100%**

MENU ENTER DOWN UP

## SYSTEM

### RESET BY DMX

**ENAB**

MENU ENTER DOWN UP

## SYSTEM

### MOTORS FW UPGRADE

MENU ENTER DOWN UP

PAN INVERSION  
Default = NORMAL



TILT INVERSION  
Default = NORMAL

PAN SPEED CONTROL  
Default = 5

TILT SPEED CONTROL  
Default = 5

ZOOM SPEED CONTROL  
Default = 1

FANS SETTING  
STUDIO or LIVE-TOUR mode  
Default = STUDIO

FAN MAX SPEED  
50% (12V) - 100% (24V)  
Default = 100%

RESET BY DMX  
Enable: Motors reset enabled via DMX (Default)  
Disabled: Motors reset disabled via DMX  
Now: Instant motors reset.

MOTORS FIRMWARE UPGRADE  
Zoom and Pan&Tilt boards  
firmware upgrade.

## 12- DISPLAY FUNCTIONS

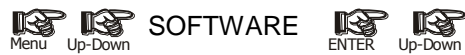

SOFTWARE  
LEDs and motors (Pan&Tilt-Zoom)  
boards software version



LEDs BOARD  
SOFTWARE VERSION



MOTORS BOARDS  
SOFTWARE VERSION  
(PAN&TILT – ZOOM)

## 13- PERIODIC CLEANING

### Front lenses Glass

The dust can reduce the luminous output substantially.  
Regularly clean the front lenses glass using a soft cotton cloth, dampened with a specialist glasses cleaning solution.

### Fans and air passages

The fans and air passages must be cleaned approximately every 6 weeks.  
This periodic cleaning will depend of course, on the conditions in which the projector is operating.  
Suitable instruments for performing this type of maintenance are a brush and a common vacuum cleaner or an air compressor.  
If necessary, clean the fans and air passages more frequently.

## 14- PERIODIC CONTROLS



### Mechanical parts

Periodically check all mechanical parts and the gaskets, replacing them if necessary.

### Electrical components

Check all electrical components for correct earthing and proper attachment of all connectors, refastening if necessary.

**Attention: Disconnect mains power prior to removing the projector housing.**



### Fuse replacement

Locate the fuse, which protect the electronics, in the base of the NICK NRG 1201. Using a multimeter, test the condition of the fuse, replacing it with one of equivalent type (T 5A 250V) if necessary.

**Attention: Disconnect mains power prior to removing the projector housing.**



**15- DMX PROTOCOL**

<b>FIRMWARE RELEASE</b>	<b>1.35</b>
<b>RDM Device Model ID</b>	<b>0x0D13</b>
<b>DMX Personality ID</b>	<b>0x01 “20CH With FAR”</b>

**20 CHANNELS MODE**

- 1 PAN
- 2 PAN FINE
- 3 TILT
- 4 TILT FINE
- 5 PAN / TILT SPEED
- 6 FPR
- 7 FREQUENCY
- 8 SHUTTER
- 9 DIMMER
- 10 RED
- 11 GREEN
- 12 BLUE
- 13 WHITE
- 14 MACRO WHITE
- 15 CTC
- 16 MACRO
- 17 FUNCTION
- 18 ZOOM
- 19 ZOOM SPEED
- 20 RESET

DMX CHANNEL	1	Parameter: <b>PAN</b>
-------------	---	-----------------------

DMX CHANNEL	2	Parameter: <b>PAN FINE</b>
-------------	---	----------------------------

DMX CHANNEL	3	Parameter: <b>TILT</b>
-------------	---	------------------------

DMX CHANNEL	4	Parameter: <b>TILT FINE</b>
-------------	---	-----------------------------

DMX CHANNEL	5	Parameter: <b>PAN / TILT SPEED</b>
-------------	---	------------------------------------

DMX range Value	Mid Point DMX value	Move Range (degrees)	Mode	Option	Function
000-010					Standard
011-025					Fast movement
026-127					Vector mode from fast to slow
128-247					Variable time reaction to DMX signal (fast to slow)
248-255					Slow reaction time to DMX signal



DMX CHANNEL	6	Parameter: <b>FPR</b>
-------------	---	-----------------------

DMX range Value	Mid Point DMX value	Move Range (degrees)	Mode	Option	Function
000-010					Position mode 540° (standard path)
011-020					Position mode 360° (1 turn)
021-030					Position mode 720° (2 turns)
031-040					Position mode 1080° (3 turns)
041-050					Position mode 1440° (4 turns)
051-060					Position mode 1800° (5 turns)
061-070					Position mode 2160° (6 turns)
071-080					Position mode 2520° (7 turns)
081-090					Position mode 2880° (8 turns)
091-100					Position mode 3240° (9 turns)
101-110					Position mode 3600° (10 turns)
111-120					Position mode 360° smart path
121-182					Forward spin rotation speed from max to min
183-193					Stop
194-255					Reverse spin rotation speed from min to max

DMX CHANNEL	7	Parameter: <b>FREQUENCY</b>
-------------	---	-----------------------------

DMX range Value	Mid Point DMX value	Move Range (degrees)	Mode	Option	Function
000-045					No function
046-055					Output frequency 610 Hz (Default)
056-065					Output frequency 800 Hz
066-075					Output frequency 1000 Hz
076-085					Output frequency 1500 Hz
086-095					Output frequency 2000 Hz
096-105					Output frequency 2500 Hz
106-115					Output frequency 3000 Hz
116-125					Output frequency 3500 Hz
126-135					Output frequency 4000 Hz
136-145					Output frequency 4500 Hz
146-155					Output frequency 5000 Hz
156-165					Output frequency 5500 Hz
166-175					Output frequency 6000 Hz
176-185					Output frequency 6500 Hz
186-195					Output frequency 7000 Hz
196-205					Output frequency 7500 Hz
206-215					Output frequency 8000 Hz
216-225					Output frequency 8500 Hz
226-235					Output frequency 9000 Hz
236-245					Output frequency 9500 Hz
246-255					Output frequency 10000 Hz

DMX CHANNEL	8	Parameter: <b>SHUTTER</b>
-------------	---	---------------------------

DMX range Value	Mid Point DMX value	Move Range (degrees)	Mode	Option	Function
000-009					<b>Black-out</b>
010-019					<b>Open</b>
020-029					<b>Black-out</b>
030-119					<b>Strobe (from 3.27 s to 30 ms)</b>
120-149					<b>Pulse up (from 42.6 s to 120 ms)</b>
150-179					<b>Pulse down (from 42.6 s to 120 ms)</b>
180-204					<b>Random strobe (Dimmer, Red, Green, Blue, White channels active)</b>
205-229					<b>Full independent Random Strobe (Dimmer, Red, Green, Blue, White channels disabled)</b>
230-255					<b>Open</b>

DMX CHANNEL	9	Parameter: <b>DIMMER</b>
-------------	---	--------------------------

DMX range Value	Mid Point DMX value	Move Range (degrees)	Mode	Option	Function
000-255					<b>Proportional dimmer</b>

DMX CHANNEL	10	Parameter: <b>RED</b>
-------------	----	-----------------------

DMX range Value	Mid Point DMX value	Move Range (degrees)	Mode	Option	Function
000-255					<b>Proportional colour</b>

DMX CHANNEL	11	Parameter: <b>GREEN</b>
-------------	----	-------------------------

DMX range Value	Mid Point DMX value	Move Range (degrees)	Mode	Option	Function
000-255					<b>Proportional colour</b>

DMX CHANNEL	12	Parameter: <b>BLUE</b>
-------------	----	------------------------

DMX range Value	Mid Point DMX value	Move Range (degrees)	Mode	Option	Function
000-255					<b>Proportional colour</b>















DMX CHANNEL	13	Parameter: <b>WHITE</b>
-------------	----	-------------------------

DMX range Value	Mid Point DMX value	Move Range (degrees)	Mode	Option	Function
000-255					<b>Proportional colour</b>







DMX CHANNEL	14	Parameter: <b>MACRO WHITE</b>
-------------	----	-------------------------------







DMX range Value	Mid Point DMX value	Move Range (degrees)	Mode	Option	Function
000-055	23				No Function
056-105	80				Full (Red-Green-Blue-White at Full)
106-155	130				White DTS
156-205	180				Custom White Create (RGBW levels selectable by DMX)
206-255	230				White CTC (Channel 15 CTC enabled)







DMX CHANNEL	15	Parameter: <b>CTC (Color Temperature Correction)</b>
-------------	----	--

DMX range Value	Mid Point DMX value	Move Range (degrees)	Mode	Option	Function
<b>IF CHANNEL 14 WHITE PREPROGRAMMED = MACRO WHITE (DMX range value 206 – 255)</b>					
IF:   LED   CTC MODE   STANDARD  (Please refer to page 16 for details)					
IF:   LED   CTC MODE   COMPATIB.  (Please refer to page 16 for details)					
000-255					Linear color temperature correction from 2700K to 8000K 0 = 2700K 255 = 8000K

DMX CHANNEL	15	Parameter: <b>CTC (Color Temperature Correction)</b>
-------------	----	--

DMX range Value	Mid Point DMX value	Move Range (degrees)	Mode	Option	Function
<b>IF CHANNEL 14 WHITE PREPROGRAMMED = MACRO WHITE (DMX range value 206 – 255)</b>					
IF:   LED   CTC MODE   EXTENDED  (Please refer to page 16 for details)					
000-255					Linear color temperature correction from 2700K to 20500K 0 = 2700K 255 = 20500K

DMX CHANNEL	16	Parameter: <b>MACRO</b>			
IF:   <b>DMX SET</b>   <b>MACRO</b>   <b>STD</b>  (Please refer to page 15 for details)					
000-014					No Function
015-030					Macro 1
031-046					Macro 2
047-062					Macro 3
063-078					Macro 4
079-094					Macro 5
095-110					Macro 6
111-126					Macro 7
127-142					Macro 8
143-158					Macro 9
159-174					Macro 10
175-190					Macro 11
191-206					Macro 12
207-222					Macro 13
223-238					Macro 14
239-254					Macro 15
255					Macro 16

DMX CHANNEL	16	Parameter: <b>MACRO</b>			
IF:   <b>DMX SET</b>   <b>MACRO</b>   <b>EXT</b>  (Please refer to page 15 for details)					
000-014					No Function
015-024					Macro 1
025-034					Macro 2
035-044					Macro 3
045-054					Macro 4
055-064					Macro 5
065-074					Macro 6
075-084					Macro 7
085-094					Macro 8
095-104					Macro 9
105-114					Macro 10
115-124					Macro 11
125-134					Macro 12
135-144					Macro 13
145-154					Macro 14
155-164					Macro 15
165-174					Macro 16
175-184					Rainbow Speed 1 (6 Sec.)
185-194					Rainbow Speed 2 (15 Sec.)
195-204					Rainbow Speed 3 (30 Sec.)
205-214					Rainbow Speed 4 (45 Sec.)
215-224					Rainbow Speed 5 (60 Sec.)
225-234					Rainbow Speed 6 (120 Sec.)
235-244					Rainbow Speed 7 (150 Sec.)
245-255					Rainbow Speed 8 (180 Sec.)

DMX CHANNEL	17	Parameter: <b>FUNCTION</b>
-------------	----	----------------------------

DMX range Value	Mid Point DMX value	Move Range (degrees)	Mode	Option	Function
<b>IF CHANNEL 14 MACRO WHITE = DMX range value (156 – 205)</b>					
000-079					Custom White Recall
080-160					Custom White Create (Enable Custom White Creation)
161-255					Custom White Store (Store the Custom White created)

DMX CHANNEL	17	Parameter: <b>FUNCTION</b>
-------------	----	----------------------------

DMX range Value	Mid Point DMX value	Move Range (degrees)	Mode	Option	Function
<b>IF CHANNEL 14 MACRO WHITE = DMX range value (000-055) IF CHANNEL 7 FREQUENCY = DMX range value (046-255)</b>					
000-079					No function
080-160					Active the output frequency selected
161-255					Store the output frequency selected

DMX CHANNEL	18	Parameter: <b>ZOOM</b>
-------------	----	------------------------

DMX range Value	Mid Point DMX value	Move Range (degrees)	Mode	Option	Function
000-255					Linear ZOOM from Narrow to Wide (8° - 50°)

DMX CHANNEL	19	Parameter: <b>ZOOM SPEED</b>			
DMX range Value	Mid Point DMX value	Move Range (degrees)	Mode	Option	Function
000-010					<b>Standard speed</b>
011-025					<b>Maximum speed</b>
026-127					<b>From maximum to minimum speed</b>
128-247					<b>Variable reaction to DMX signal (fast to slow)</b>
248-255					<b>Slow reaction time to DMX signal</b>

DMX CHANNEL	20	Parameter: <b>RESET</b>			
DMX range Value	Mid Point DMX value	Move Range (degrees)	Mode	Option	Function
000-015					<b>No Function</b>
016-255					<b>Total unit reset (after 3 seconds)</b>

NOTES

PROUDLY  
MADE IN ITALY



DTS products are designed  
and manufactured at the  
DTS plants in Italy



**ISO 9001:2008**

DTS quality system is certified  
to the ISO 9001:2008 standard

**D.T.S. Illuminazione s.r.l.** • Via Fagnano Selve 12-14  
47843 Misano Adriatico (RN) Italy  
Tel.: +39 0541 611131 • Fax +39 0541 611111  
[info@dts-lighting.it](mailto:info@dts-lighting.it) • [www.dts-lighting.it](http://www.dts-lighting.it)



**05171196**