

# OWNER MANUAL MANUALE D'USO

**C 5212-64**  
**C 5212-66**  
**C 5212-94**  
**C 5212-96**  
**C 5212-99**

**C 5215-64**  
**C 5215-66**  
**C 5215-94**  
**C 5215-96**  
**C 5215-99**

- 'COMPACT' SERIES  
LOUDSPEAKERS
- DIFFUSORI ACUSTICI DELLA  
SERIE "COMPACT"



**IMPORTANT NOTES**

Before connecting and using this product, please read this instruction manual carefully and keep it on hand for future reference. This manual is to be considered an integral part of this product and must accompany it when it changes ownership as a reference for correct installation and use as well as for the safety precautions.

**RCF S.p.A.** will not assume any responsibility for the incorrect installation and / or use of this product.

**WARNING:** To prevent the risk of fire or electric shock, never expose this loudspeaker to rain or humidity and also dust.

**SAFETY AND OPERATING PRECAUTIONS**

**1.** All the precautions, in particular the safety ones, must be read with special attention, as they provide important information.

**2.** Loudspeaker lines (amplifier outputs) can have a sufficiently high voltage to involve a risk of electrocution: never install or connect this loudspeaker when amplifiers are switched on.

**3.** Make sure all connections have been made correctly and the loudspeaker input impedance is suitable for the amplifier output.

**4.** Protect loudspeaker lines from damage; make sure they are positioned in a way that they cannot be stepped on or crushed by objects.

**5.** Make sure that no objects or liquids can get into this product, as this may cause a short circuit.

**6.** Never attempt to carry out any operations, modifications or repairs that are not expressly described in this manual.

Contact your authorized service centre or qualified personnel should any of the following occur:

- The loudspeaker does not function (or works in an anomalous way).
- The cable has been damaged.
- Objects or liquids are inside the loudspeaker.
- The loudspeaker has been damaged due to heavy impacts or fire.

**7.** Should the loudspeaker emit any strange odours or smoke, remove it from the line after having immediately switched the amplifier off.

**8.** Do not connect this product to any equipment or accessories not foreseen.

For suspended installation, only use the dedicated anchoring points and do not try to hang this loudspeaker by using elements that are unsuitable or not specific for this purpose.

Also check the suitability of the support surface to which the product is anchored (wall, ceiling, structure, etc.), and the components used for attachment (screw anchors, screws, brackets not supplied by RCF etc.), which must guarantee the security of the system / installation over time, also considering, for example, the mechanical vibrations normally generated by transducers.

**9.** **RCF S.p.A.** strongly recommends this product is only installed by professional qualified installers (or specialised firms) who can ensure a correct installation and certify it according to the regulations in force.

The entire audio system must comply with the current standards and regulations regarding electrical systems.

**IMPORTANT**

**10.** Mechanical and electrical factors need to be considered when installing a professional audio system (in addition to those which are strictly acoustic, such as sound pressure, angles of coverage, frequency response, etc.).

**11. Hearing loss**

Exposure to high sound levels can cause permanent hearing loss. The acoustic pressure level that leads to hearing loss is different from person to person and depends on the duration of exposure.

To prevent potentially dangerous exposure to high levels of acoustic pressure, anyone who is exposed to these levels should use adequate protection devices.

When a transducer capable of producing high sound levels is being used, it is necessary to wear ear plugs or protective earphones.

See the technical specifications in the instruction manual for the maximum sound pressure the loudspeaker is capable of producing.

**12.** To ensure a correct sound reproduction, loudspeaker phase is to be respected (loudspeakers are connected respecting the amplifier polarity). This is important when loudspeakers are installed adjacent one another, for instance, in the same room.

**13.** To prevent inductive effects from causing hum, noise and a bad system working, loudspeaker lines should not be laid together with other electric cables (mains), microphone or line level signal cables connected to amplifier inputs.

**14.** The loudspeaker cable shall have wires (twisted, if possible, to reduce inductive effects due to surrounding electro-magnetic fields) with a suitable section and a sufficient electrical insulation. Refer to local regulations since there may be additional requirements about cable characteristics.

**15.** Do NOT connect the loudspeaker low impedance (8  $\Omega$ ) input to 70 / 100 V constant voltage lines.

**16.** Install this loudspeaker far from any heat source.

**17.** Do not overload the loudspeaker with too much power.

**18.** Do not use solvents, alcohol, benzene or other volatile substances for cleaning the external parts of this product. Use a dry cloth.

RCF S.P.A. THANKS YOU FOR PURCHASING THIS PRODUCT, WHICH HAS BEEN DESIGNED TO GUARANTEE RELIABILITY AND HIGH PERFORMANCE.

## DESCRIPTION



The new 'Compact' series includes a wide range of high quality 2-way passive loudspeakers for fixed installations. It is based on the RCF exclusive 'Coverage Matching Design' technology, that helps guarantee an optimal transition between the high frequency horn polar pattern and the low frequency woofer directivity.

The horn can be rotated, allowing to install the loudspeaker either vertically or horizontally.

This manual covers 2 models of the new series:

- **C 5212** two-way loudspeaker, 12" woofer (3" voice coil) and 1.4" driver (2.5" voice coil)
- **C 5215** two-way loudspeaker, 15" woofer (3" voice coil) and 1.4" driver (2.5" voice coil)

The C 5212 and C 5215 models are available with 5 different horn dispersions, indicated by 5 different suffixes:

- **C 5212-64**, C 5212 having 60° (horizontal) x 40° (vertical) dispersion
- **C 5212-66**, C 5212 having 60° (horizontal) x 60° (vertical) dispersion
- **C 5212-94**, C 5212 having 90° (horizontal) x 40° (vertical) dispersion
- **C 5212-96**, C 5212 having 90° (horizontal) x 60° (vertical) dispersion
- **C 5212-99**, C 5212 having 90° (horizontal) x 90° (vertical) dispersion
- **C 5215-64**, C 5215 having 60° (horizontal) x 40° (vertical) dispersion
- **C 5215-66**, C 5215 having 60° (horizontal) x 60° (vertical) dispersion
- **C 5215-94**, C 5215 having 90° (horizontal) x 40° (vertical) dispersion
- **C 5215-96**, C 5215 having 90° (horizontal) x 60° (vertical) dispersion
- **C 5215-99**, C 5215 having 90° (horizontal) x 90° (vertical) dispersion.

### HOW TO REMOVE THE GRILLE TO HAVE ACCESS TO THE HORN

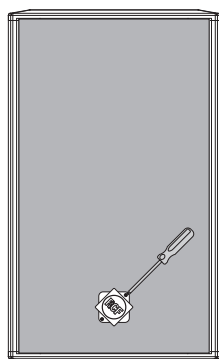

Rotate the RCF Logo 45° to show the two screw heads, then remove the screws.

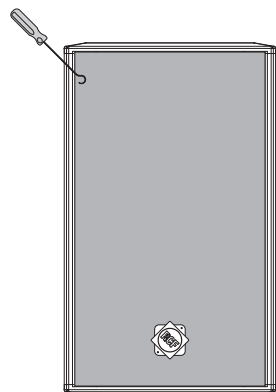

Using a hook, pass through the foam layer and try to locate a hole on a side of the metal grille

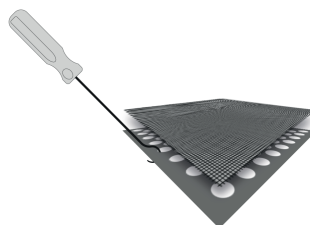

Notice the metal grille is located under a foam layer.  
THE HOOK MUST BE HANGED TO THE METAL GRILLE.  
DO NOT PULL IF THE HOOK IS HANGED TO THE FOAM LAYER.

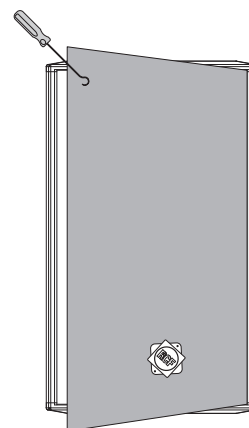

Once the hook is hanged to the metal grille, pull gently. The grille should now lift and can be removed

All models are carefully assembled in Italy (in our main factory) and include RCF woofers and drivers that are the best of the most recent technology about transducers.

All loudspeakers are equipped with a high power handling 'Low Impedance Compensated Crossover', having an electronic protection for the driver.

It is also possible to choose the "bi-amp" mode (an amplifier for low frequencies and another one for high frequencies) by using an external crossover.

All cabinets are made of Baltic birch plywood (heavy duty painted) and allow different installation options.

The steel front grilles are protected with a robust double mesh polyester clothing.

The front RCF logo is easily rotatable.

All models are equipped with top and bottom 'Multiplates' for either wall or suspended mounting with chains.

Installation points are available on rear panels.

All models have two Neutrik Speakon NL4 connectors (audio input and parallel link output).



Loudspeakers are to be installed by qualified personnel, respecting all safety standards. Loudspeakers are to be installed securely. Make sure the support structure (walls / ceilings) has the necessary mechanical characteristics for the loudspeaker weight, without the risk of a fall that could damage things or cause an injury. Use attachments elements suitable for walls / ceilings (e.g. wall plugs for bricks, concrete, etc.).



## a) HORIZONTAL MOUNTING WITH U BRACKET

### NECESSARY OPTIONAL ACCESSORY:

- AC NC12 H-BR (for the C 5212-64, C 5212-66, C 5212-94, C 5212-96, C 5212-99 models)
- AC NC15 H-BR (for the C 5215-64, C 5215-66, C 5215-94, C 5215-96, C 5215-99 models).

Fix the U bracket to the wall / ceiling through at least 4 lateral wall plugs (max. M8) plus a central one (max. M10).

Mount the U bracket to the loudspeaker by tightening the two M10x35 bolts into the two central holes of the multiplates, as shown in the figure below.

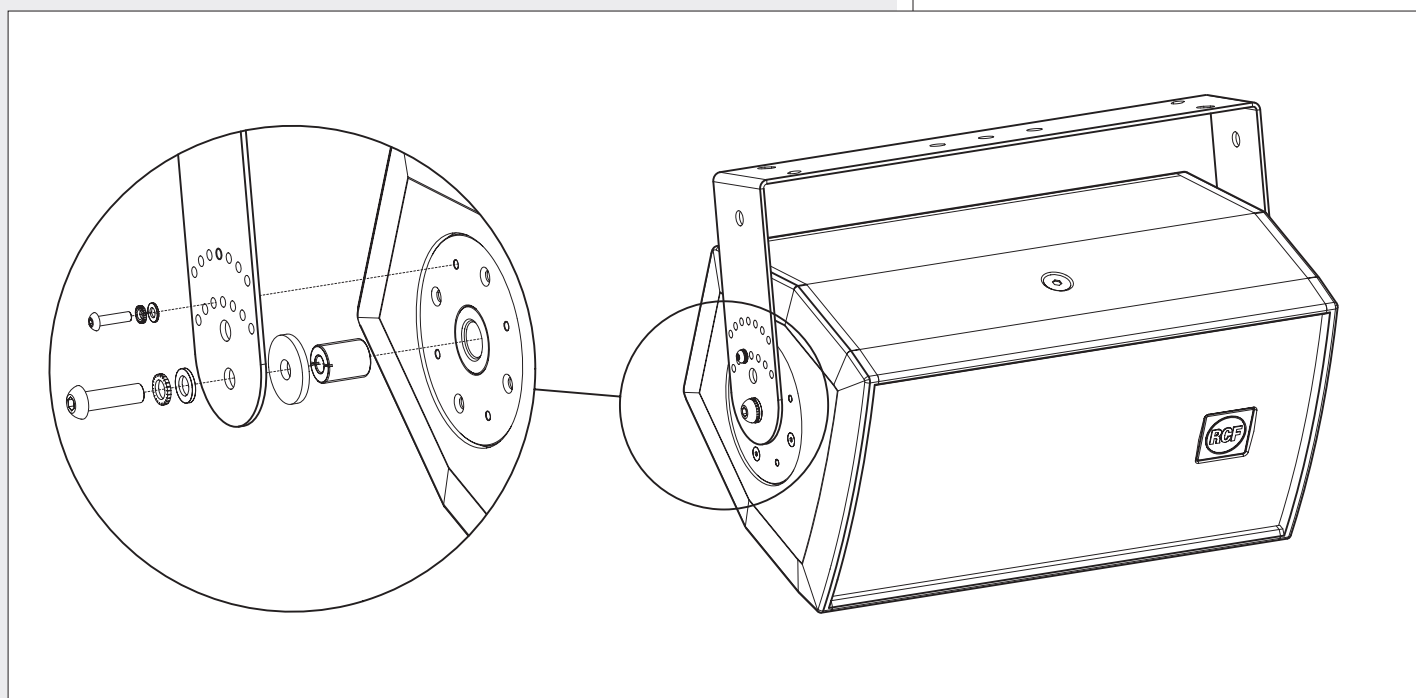

As an alternative, it is possible to install the loudspeaker a bit less prominent, thanks to the U bracket inner holes. Before tightening the two M10 bolts, adjust the loudspeaker vertical tilt and then fix it through two M5x20 bolts into one of the 7 small holes of the U bracket.

NOTE: DO NOT TILT THE LOUDSPEAKER UPWARDS!

INSTEAD OF SIMPLE M10 BOLTS, IT IS POSSIBLE TO USE THE INCLUDED KNOBS (HAVING M10 BOLTS).



## b) VERTICAL MOUNTING WITH U BRACKET

### NECESSARY OPTIONAL ACCESSORY:

- AC NC12 V-BR  
(for the C 5212-64, C 5212-66, C 5212-94, C 5212-96, C 5212-99 models)
- AC NC15 V-BR  
(for the C 5215-64, C 5215-66, C 5215-94, C 5215-96, C 5215-99 models).

Fix the U bracket to the wall / ceiling through at least 4 lateral wall plugs (max. M8) plus a central one (max. M10).

Mount the U bracket to the loudspeaker by tightening the two M10x35 bolts into the two lateral holes of the loudspeaker, as shown in the figure below.

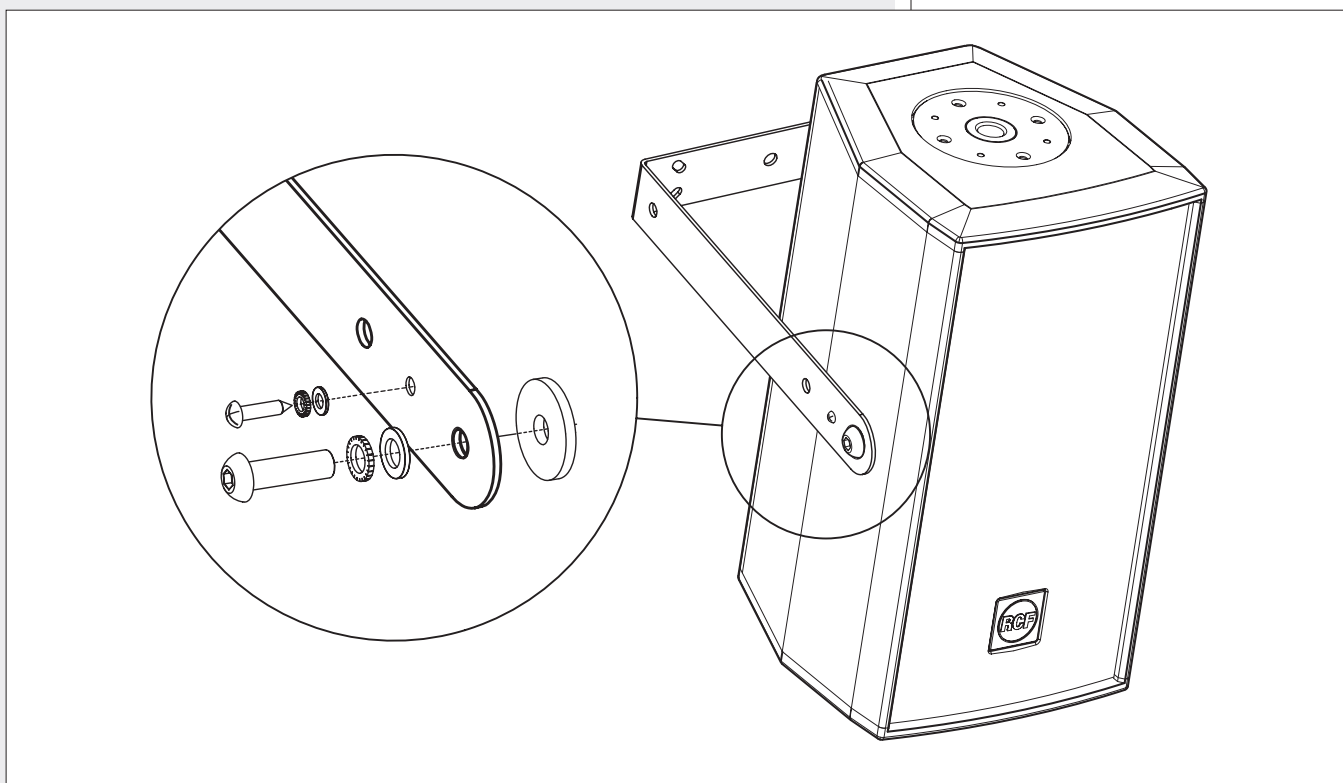

As an alternative, it is possible to install the loudspeaker a bit less prominent, thanks to the U bracket inner holes.

Before tightening the two M10 bolts, adjust the loudspeaker vertical tilt and then fix it through two M4.2x22 self-threading screws (passing through the small hole of the U bracket) directly into the loudspeaker cabinet wood.

Note: do NOT tilt the loudspeaker upwards!

Instead of simple M10 bolts, it is possible to use the included knobs (having M10 bolts).

### c) SUSPENDED MOUNTING WITH A DEDICATED ACCESSORY

#### NECESSARY OPTIONAL ACCESSORY: AC NC-FB2

The AC NC-FB2 accessory is a bracket with holes that allows the loudspeaker suspension with two M10 D-shackles and chains (not included).

Fix the AC NC-FB2 accessory to the loudspeaker top multiplate through four M5 flat head, as shown in the figure below.

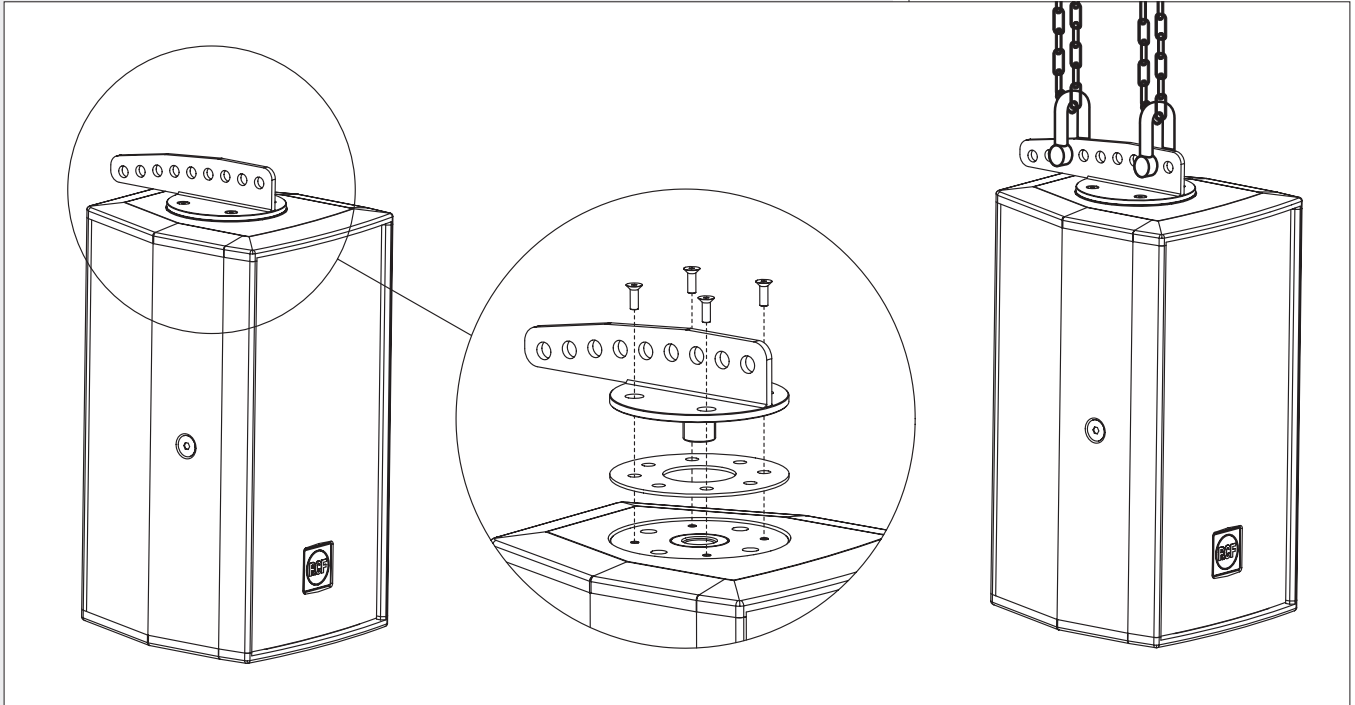



**WARNING:** loudspeaker connections should be only made by qualified and experienced personnel having the technical know-how or sufficient specific instructions (to ensure that connections are made correctly) in order to prevent any electrical danger. To prevent any risk of electric shock, do not connect loudspeakers when the amplifier is switched on.

Before turning the system on, check all connections and make sure there are no accidental short circuits.

The entire sound system shall be designed and installed in compliance with the current local laws and regulations regarding electrical systems.

'Compact' series loudspeakers are designed for indoor use only. If installed outdoor, loudspeakers shall be protected against water.

On each rear panel:

- A switch to select either 'FULL RANGE' (one amplifier and use of the internal crossover) or 'BI-AMP' (bi-amplification and external crossover)
- 2 sockets (input and output, linked in parallel) for 'Neutrik Speakon NL4' (4-pole) plugs.

**'FULL RANGE' MODE**

The impedance value of each loudspeaker is 8 Ω.

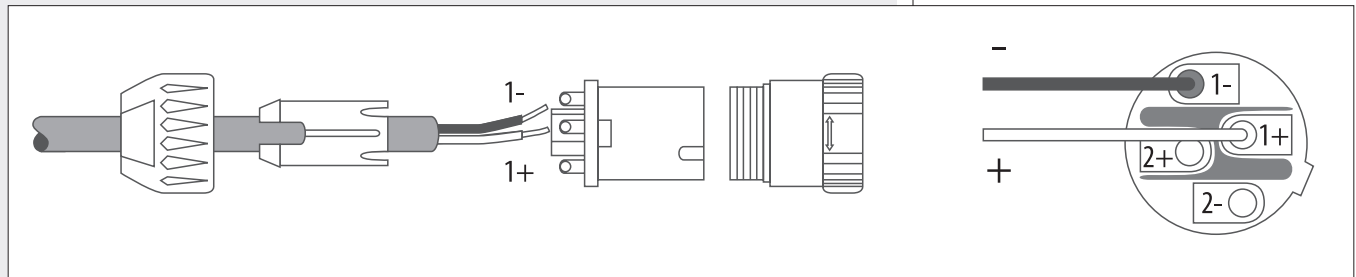
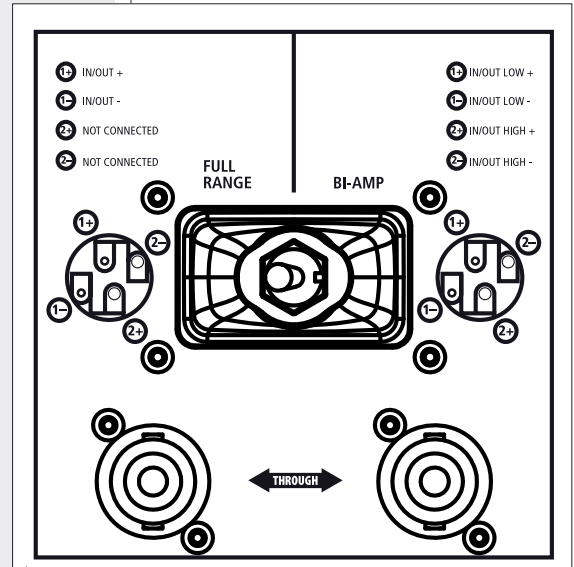

Connect the positive wire (amplifier '+' output) to the pin 1+ of the SPEAKON connector. Connect the negative wire (amplifier '-' output) to the pin 1- of the SPEAKON connector. The pins 2+ and 2- are not used.

**'BI-AMP' MODE**

Two amplifiers are necessary (one for low frequencies, one for high frequencies) and an external crossover.

See in the specification table the impedance of each way, the handling power and the suggest crossover frequency.

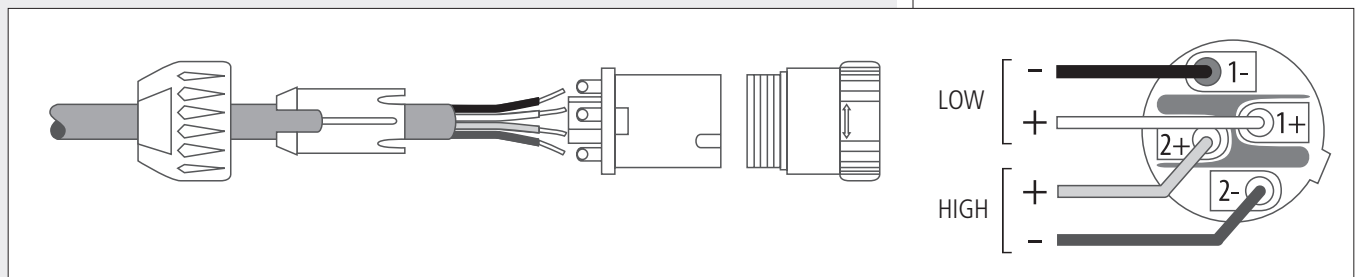
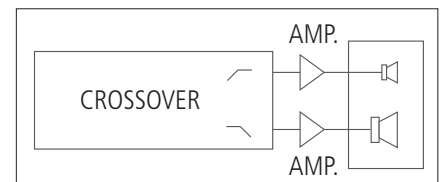

Connections:

- Low frequency amplifier + output to the pin 1+ of the SPEAKON connector
- Low frequency amplifier - output to the pin 1- of the SPEAKON connector
- High frequency amplifier + output to the pin 2+ of the SPEAKON connector
- High frequency amplifier - output to the pin 2- of the SPEAKON connector.



## NOTES ABOUT LOW IMPEDANCE CONNECTIONS



- The total loudspeaker impedance must not be lower than the amplifier output impedance. Note: a loudspeaker total impedance equal to the amplifier output one permits to get the maximum deliverable power (but an higher loudspeaker impedance entails less power).
- The total loudspeaker power shall be adequate for the maximum deliverable power of the amplifier.
- The loudspeaker line shall be short (for long distances, it may be necessary to use cables with large cross-section wires).

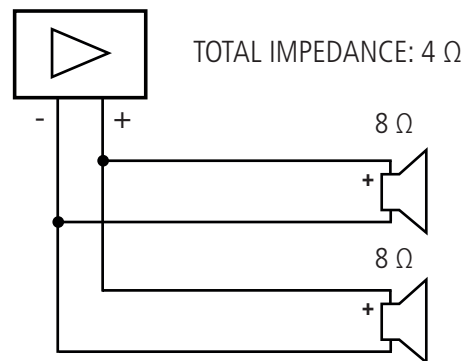
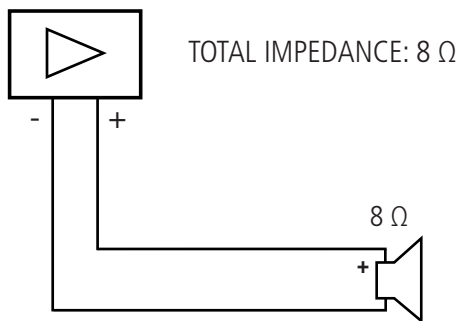

- Always use cables having wires with an adequate cross-section, considering the cable length and the total loudspeaker power.
- Loudspeaker lines must be kept separated from the mains cables, microphone cables or others, in order to avoid inductive phenomena may cause hum or noises.
- Use loudspeaker cables with twisted wires to reduce hum caused by inductive effects due to coupling with electromagnetic fields.
- Do NOT connect the low impedance input directly to 70 / 100 V constant voltage lines.



CABINET: birch plywood      COLOUR: black

MODEL	C 5212-64	C 5212-66	C 5212-94	C 5212-96	C 5212-99
IMPEDANCE ('full range')	8 Ω	8 Ω	8 Ω	8 Ω	8 Ω
RMS POWER, ("full-range")	500 W	500 W	500 W	500 W	500 W
IMPEDANCES ('bi-amp')	8 Ω (LF) 8 Ω (HF)	8 Ω (LF) 8 Ω (HF)	8 Ω (LF) 8 Ω (HF)	8 Ω (LF) 8 Ω (HF)	8 Ω (LF) 8 Ω (HF)
AES POWERS ('bi-amp')	400 W (LF) 100 W (HF)	400 W (LF) 100 W (HF)	400 W (LF) 100 W (HF)	400 W (LF) 100 W (HF)	400 W (LF) 100 W (HF)
CROSSOVER FREQUENCY	1.2 kHz	1.2 kHz	1.2 kHz	1.2 kHz	1.2 kHz
FREQUENCY RESPONSE (-10 dB)	60 Hz ÷ 20 kHz	60 Hz ÷ 20 kHz	60 Hz ÷ 20 kHz	60 Hz ÷ 20 kHz	60 Hz ÷ 20 kHz
SENSITIVITY (1 W / 1 m)	98 dB	98 dB	98 dB	98 dB	98 dB
SPL (1 m)	125 dB (500 W)	125 dB (500 W)	125 dB (500 W)	125 dB (500 W)	125 dB (500 W)
WOOFER	12" (3" v.c.)	12" (3" v.c.)	12" (3" v.c.)	12" (3" v.c.)	12" (3" v.c.)
DRIVER	1.4" (2.5" v.c.)	1.4" (2.5" v.c.)	1.4" (2.5" v.c.)	1.4" (2.5" v.c.)	1.4" (2.5" v.c.)
DISPERSION (hor. x vert.)	60° x 40°	60° x 60°	90° x 40°	90° x 60°	90° x 90°
NET WEIGHT	29 kg	29 kg	29 kg	29 kg	29 kg

MODEL	C 5215-64	C 5215-66	C 5215-94	C 5215-96	C 5215-99
IMPEDANCE ('full range')	8 Ω	8 Ω	8 Ω	8 Ω	8 Ω
RMS POWER, ("full-range")	500 W	500 W	500 W	500 W	500 W
IMPEDANCES ('bi-amp')	8 Ω(LF)-8 Ω(HF)	8 Ω(LF)-8 Ω(HF)	8 Ω(LF)-8 Ω(HF)	8 Ω(LF)-8 Ω(HF)	8 Ω(LF)-8 Ω(HF)
AES POWERS ('bi-amp')	400 W (LF) 100 W (HF)	400 W (LF) 100 W (HF)	400 W (LF) 100 W (HF)	400 W (LF) 100 W (HF)	400 W (LF) 100 W (HF)
CROSSOVER FREQUENCY	1.2 kHz	1.2 kHz	1.2 kHz	1.2 kHz	1.2 kHz
FREQUENCY RESPONSE (-10 dB)	55 Hz ÷ 20 kHz	55 Hz ÷ 20 kHz	55 Hz ÷ 20 kHz	55 Hz ÷ 20 kHz	55 Hz ÷ 20 kHz
SENSITIVITY (1 W / 1 m)	99 dB	99 dB	99 dB	99 dB	99 dB
SPL (1 m)	126 dB (500W)	126 dB (500W)	126 dB (500W)	126 dB (500W)	126 dB (500W)
WOOFER	15" (3" v.c.)	15" (3" v.c.)	15" (3" v.c.)	15" (3" v.c.)	15" (3" v.c.)
DRIVER	1.4" (2.5" v.c.)	1.4" (2.5" v.c.)	1.4" (2.5" v.c.)	1.4" (2.5" v.c.)	1.4" (2.5" v.c.)
DISPERSION (hor. x vert.)	60° x 40°	60° x 60°	90° x 40°	90° x 60°	90° x 90°
NET WEIGHT	34.8 kg	34.8 kg	34.8 kg	34.8 kg	34.8 kg

# C 5212 DIMENSIONS mm

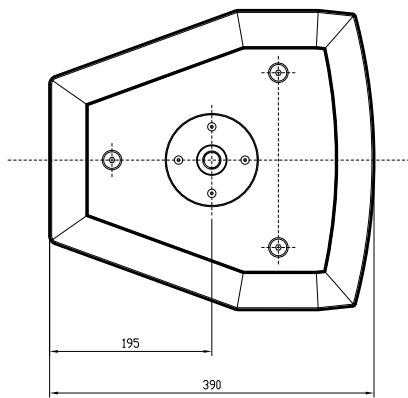
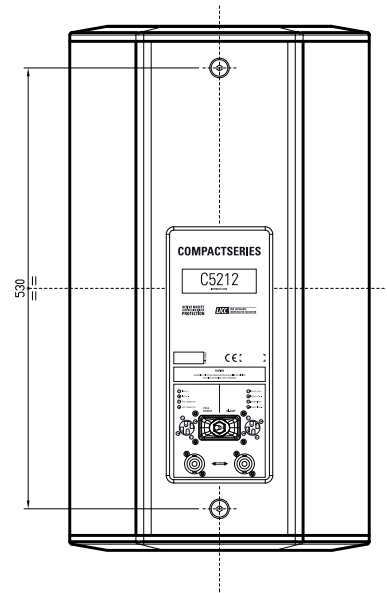
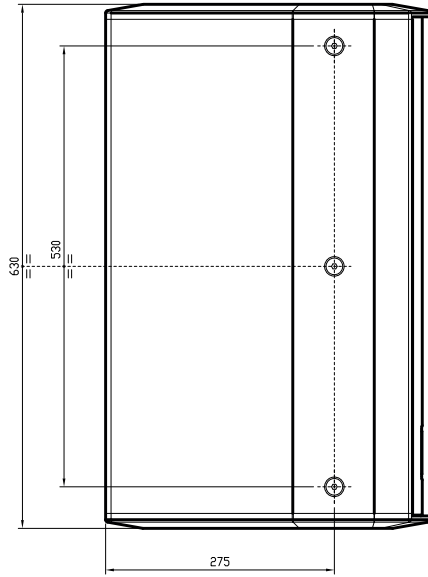
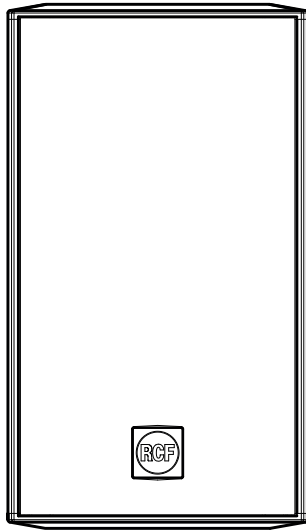

# C 5215 DIMENSIONS mm

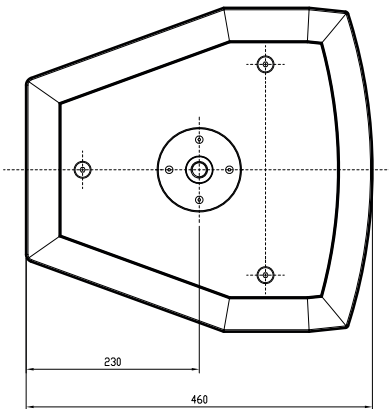
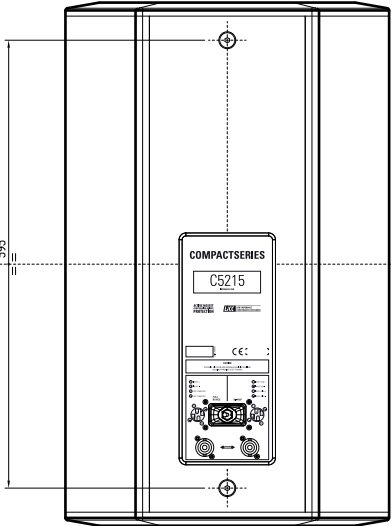
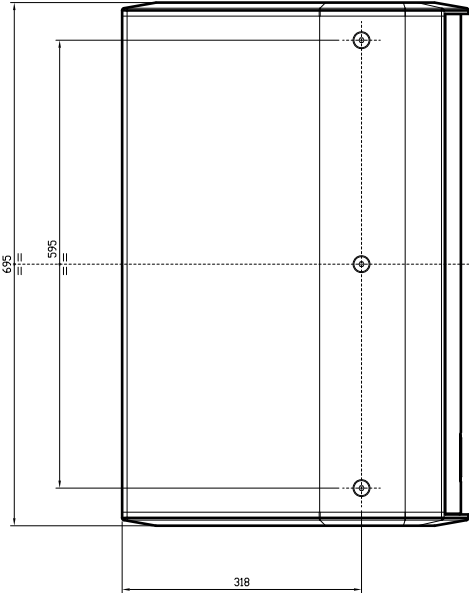
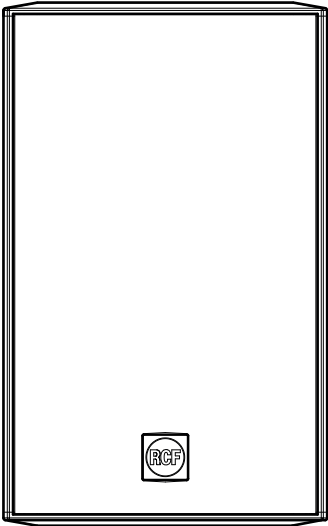

Except possible errors and omissions.  
RCF S.p.A. reserves the right to make modifications without prior notice.

Salvo eventuali errori ed omissioni.  
RCF S.p.A. si riserva il diritto di apportare modifiche senza preavviso.

**HEADQUARTERS:**

**RCF S.p.A. Italy**  
tel. +39 0522 274 411  
e-mail: info@rcf.it

**RCF UK**  
tel. 0844 745 1234  
Int. +44 870 626 3142  
e-mail: info@rcfaudio.co.uk

**RCF France**  
tel. +33 1 49 01 02 31  
e-mail: france@rcf.it

**RCF Germany**  
tel. +49 2203 925370  
e-mail: germany@rcf.it

**RCF Spain**  
tel. +34 91 817 42 66  
e-mail: info@rcfaudio.es

**RCF Belgium**  
tel. +32 (0) 3 - 3268104  
e-mail: belgium@rcf.it

**RCF USA Inc.**  
tel. +1 (603) 926-4604  
e-mail: info@rcf-usa.com



[www.rcfaudio.com](http://www.rcfaudio.com)